

Volvo Construction Equipment
Building Tomorrow



EC480E

Volvo Excavators 48.0 - 50.5 386 hp



E is for efficiency

Introducing the EC480E crawler excavator from Volvo – a powerful and efficient production machine designed to reduce fuel consumption and increase productivity. With advanced technology including Volvo's unique ECO mode and a new electro-hydraulic control system, the EC480E delivers fuel efficiency improvement.

Advanced hydraulics

The new electro-hydraulic system uses intelligent technology to control on-demand flow and reduce internal losses in the hydraulic circuit. This increases controllability, shortens cycle times and improves fuel efficiency – resulting in higher productivity and performance.



Work modes

Volvo's unique, integrated work mode system now includes the G4 mode for optimum fuel efficiency and machine performance. Operators can choose the best work mode for the task at hand – select from I (Idle), F (Fine), G (General), H (Heavy) and P (Power max).



Fuel consumption display

A gauge bar on the monitor measures both instantaneous fuel consumption and average fuel consumption. This allows machine owners and operators to monitor fuel usage on different job sites.



Automatic idling system

Engine speed is reduced to idle when the controls are inactive for a pre-set amount of time (between 3 and 20 seconds). This reduces fuel consumption and noise.

Auto engine shut down

To reduce fuel consumption, the engine will automatically switch off when the machine is inactive for a pre-set amount of time (five minutes is the default setting).



ECO MODE

Volvo's unique ECO mode optimizes the hydraulic system to reduce flow and pressure losses – resulting in improved fuel efficiency without any loss of performance in most operating conditions. ECO mode is automatically selected but can be switched off via the keypad.



HUMAN MACHINE INTERFACE (HMI)

All machine interfaces – including the joysticks, keypad and LCD monitor – are ergonomically positioned and designed for optimum control and efficiency. For operator convenience and ease of use, the number of switches has been significantly reduced.

Productivity at your fingertips

The EC480E has been expertly designed with both the machine owner and operator in mind. With ideally placed controls and switches and a user-friendly LCD monitor and keypad, the task at hand becomes easier and operators will work with increased efficiency – resulting in more productivity.

Keypad

The optimally positioned keypad allows the operator to easily navigate through the LCD monitor and activate machine functions in a safe and comfortable way. The functionality of the camera, air conditioning and lights can be customized via the hot key – enabling the operator to select and save desired configurations.



LCD monitor

The new, color, eight inch LCD monitor displays machine status information including fuel consumption data and service interval alerts – enabling increased uptime and high productivity. The user-friendly design is easy to read in any light conditions.



Shortcut switch

The windshield wipers, camera, audio mute or power max function can be assigned to a shortcut switch located on the joystick. This allows the operator to easily control the selected function by simply pressing a switch.



Seatbelt warning alarm

If the seatbelt is not fastened when the ignition key is turned, a sensor triggers an alarm which sounds for three seconds.

Bluetooth®

For added convenience, operators can now connect a Bluetooth device to the machine.

The source of productivity

Volvo puts customer needs at the heart of its design process. That's why the EC480E not only increases productivity with 5% faster cycle times, but also improves fuel efficiency and meets the latest Stage V engine emission legislation. Capitalize on high torque at low rpm and experience superior performance and reduced fuel consumption.

Volvo After Treatment System

During the fully automatic regeneration process, particulate matter in the Diesel Particulate Filter is oxidized at low exhaust temperatures via passive regeneration. Volvo uses Selective Catalytic Reduction technology where AdBlue®/Diesel Exhaust Fluid is heated to produce ammonia. This causes a chemical reaction which converts NOx to nitrogen and CO2 – both of which are naturally found in the air. Neither process interrupts machine operation, performance or productivity. ® = registered trademark of the Verband der Automobilindustrie e.V. (VDA)



Diesel-driven heater

The optional diesel-driven coolant heater helps to start the engine in low temperatures while simultaneously heating the cab. The heater can be set in advance to engage at a specific date and time.



Cooling fan

The hydraulically-driven, electronically controlled cooling fan regulates the temperature of the vital components. It automatically activates only when needed – reducing fuel consumption and noise. The optional reversible functionality – which blows air in the opposite direction – enables self-cleaning of the cooling units.





VOLVO ENGINE

Featuring proven, advanced technology and built on decades of experience, Volvo's robust D13 Stage V engine boasts more power while reducing both fuel consumption and emissions and delivering superior quality, reliability and durability.



REINFORCED UNDERCARRIAGE

With a strong three-piece undercarriage and a high strength tensile steel X-shaped frame, Volvo excavators are built to withstand tough conditions. For superior durability, the undercarriage components are reinforced – ensuring long life and high uptime.

Reinforced quality

If you're looking for a strong and reliable excavator to handle tough conditions then look no further than the EC480E. Whether you're working on a quarry, in mass excavation or any other application, this robust, heavy-duty production machine has the quality and durability you need to work on demanding job sites.

Superstructure undercover

The heavy-duty superstructure undercover plates increase durability by providing additional protection to the underside of the machine in tough applications – preventing damage from rock and debris.



Doors and hinges

Volvo's durable design features a rigid side door with a robust handle and hinges for superior durability.



Robust design

The reinforced idler frame, track links and bottom rollers are built to withstand tough conditions for improved durability and reliability in demanding applications.



Upping your uptime

Maintaining and servicing construction equipment is essential in order to sustain maximum performance and productivity – but this shouldn't be a complicated or time consuming task. With large, wide opening compartment doors and grouped service points, Volvo makes maintenance easy. Increase your uptime with Volvo.

Service access

Grouped filters are quick and easy to access from ground level. To facilitate fast servicing, grouped greasing points are easily accessed with the machine in one position.



Anti-slip plates

Punched anti-slip plates provide superior grip and increased safety. The design facilitates easy cleaning.



Storage space

A large storage compartment provides a safe and convenient location for items including a toolbox and grease can.



Handrails

Handrails and full size guardrails fold-able provide safe and easy access to the cab and superstructure. The fold-able guardrail is to minimize transportation height when it is folded.

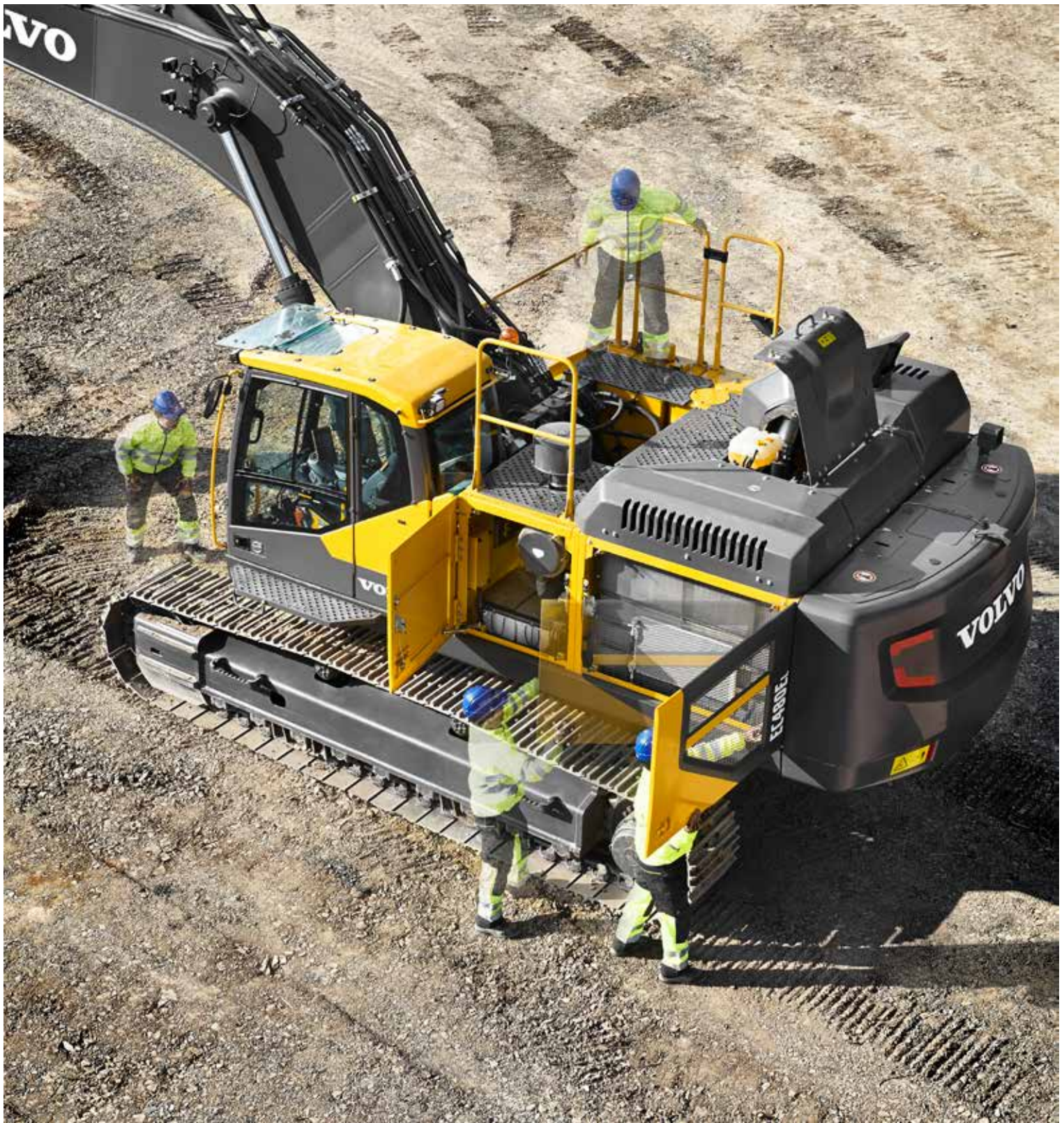

SINGLE MODULE COOLER

The radiator, charged air cooler and hydraulic oil cooler are situated side-by-side on a single layer to maximize efficiency, reduce blockages and aid cleaning. The system is easily accessed from ground level by simply opening the side door.



ATTACHMENTS

Volvo's durable attachments have been purposebuilt to work in perfect harmony with Volvo machines, forming one solid, reliable unit. With functions and properties ideally matched, Volvo attachments are an integrated part of the excavator for which they're intended – delivering maximum productivity.

The perfect match

Maximize your productivity and profitability with the EC480E and Volvo's durable range of attachments. Increase your versatility, access more applications and effectively perform a variety of tasks – all while experiencing faster cycle times and excellent control. Get the most out of your excavator with Volvo.

Bucket range

Volvo's general purpose buckets are the perfect tool for digging and re-handling in soft to medium conditions. Heavy-duty buckets are intended for productive digging in compact materials. Both provide maximum productivity and long life.



Optional auxiliary hydraulics

Factory fitted breaker and shear piping (X1) as well as tilt and rotator piping (X3) increase versatility by enabling a wide range of additional attachments to be used.

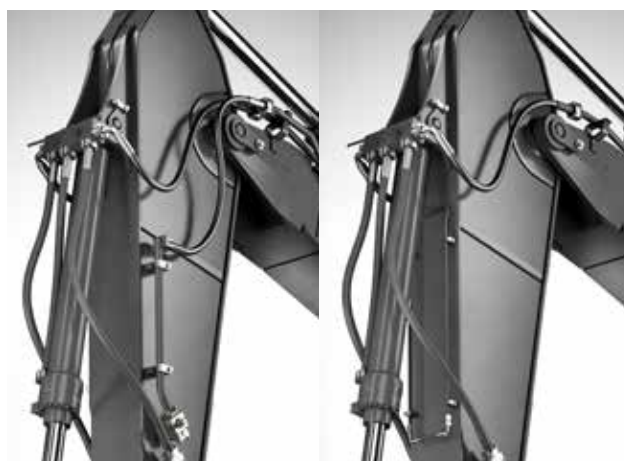

S-type quick coupler

The Volvo S-type quick coupler is designed to work with Volvo attachments – delivering ultimate compatibility and unrivalled performance.



Universal quick coupler

The Volvo universal quick coupler offers maximum versatility. It picks up a variety of attachments from various manufacturers and meets new safety regulations.



Genuine Volvo wear parts

Volvo offers a selection of economic, replaceable wear parts including high quality teeth, segments, side cutters, adapters and shrouds to protect the bucket and ensure long life.

Do more

Safe access

Punched anti-slip plates, handrails and full size fold-able guardrails provide safe and easy access to the machine.

HUMAN MACHINE INTERFACE (HMI)

All machine interfaces are ergonomically positioned and designed for optimum control and efficiency.

Advanced hydraulics

New electro-hydraulic system and main control valve use intelligent technology to control on-demand flow for high performance and efficiency.

Universal quick coupler

The Volvo quick coupler offers maximum versatility, picking up a wide variety of attachments.

ATTACHMENTS

Volvo's durable attachments have been purpose-built to deliver maximum productivity and long service life in combination with Volvo machines.

REINFORCED UNDERCARRIAGE

The undercarriage components are reinforced to ensure long life, high uptime and ultimate durability in tough conditions.

Volvo After Treatment System

The automatic regeneration process takes place without interrupting machine operation, performance or productivity.



AdBlue®

Volvo offers a total AdBlue solution that is quality assured, cost efficient and easily accessible. Contact your Volvo dealer for more information. ® = registered trademark of the Verband der Automobilindustrie e.V. (VDA)

LCD monitor

The new, eight inch LCD monitor clearly displays machine status information for easy operation and increased productivity.

ECO MODE

Volvo's unique ECO mode improves fuel efficiency without any loss of performance in most operating conditions.

Service access

Grouped filters are quick and easy to access from ground level via large, wide compartment doors.

VOLVO ENGINE

Volvo's D13 Stage V engine boasts more power while reducing both fuel consumption and emissions and delivering superior quality, reliability and durability.

SINGLE MODULE COOLER

The radiator, charged air cooler and hydraulic oil cooler are situated side-by-side on a single layer to maximize efficiency, reduce blockages and aid cleaning.

Adding value to your business

Being a Volvo customer means having a complete set of services at your fingertips. Volvo can offer you a long-term partnership, protect your revenue and provide a full range of customer solutions using high quality parts, delivered by passionate people. Volvo is committed to increasing the positive return on your investment and maximising uptime.

Complete Solutions

Volvo has the right solution for you. So why not let us provide all your needs throughout the whole life cycle of your machine? By listening to your requirements, we can reduce your total cost of ownership and increase your revenue.

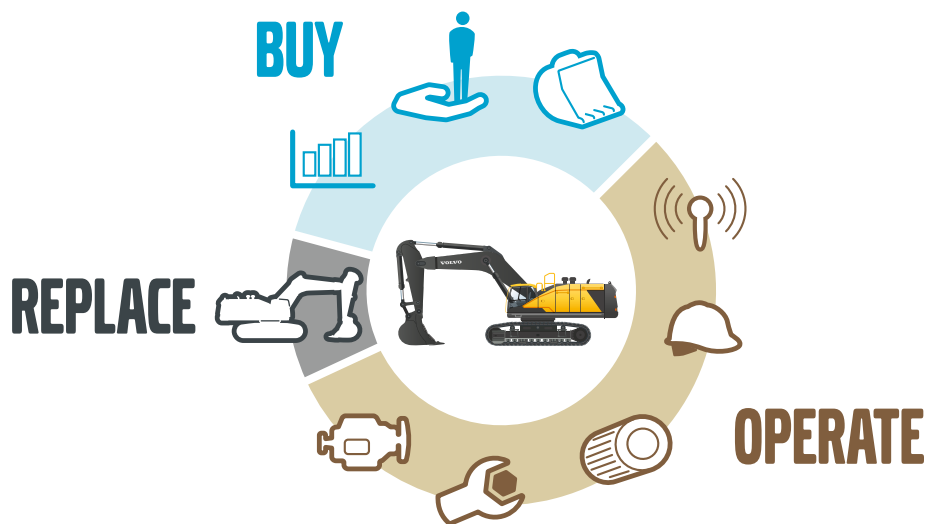

Genuine Volvo Parts

Our attention to detail is what makes us stand out. This proven concept acts as a solid investment in your machine's future. Parts are extensively tested and approved because every part is vital for uptime and performance. Only by using Genuine Volvo Parts, can you be sure that your machine retains the renowned Volvo quality.



Service Network

In order to respond to your needs faster, a Volvo expert is on their way to your job site from one of our Volvo facilities. With our extensive infrastructure of technicians, workshops and dealers, Volvo has a comprehensive network to fully support you using local knowledge and global experience.





CUSTOMER SUPPORT AGREEMENTS

The range of Customer Support Agreements offer preventive maintenance, total repairs and a number of uptime services. Volvo uses the latest technology to monitor machine operation and status, giving you advice to increase your profitability. By having a Customer Support Agreement you are in control of your service costs.

Volvo EC480E in detail

Engine

The latest generation, Volvo engine Stage V emissions certified diesel engine fully meets the demands of the latest, emissions regulations. Featuring Volvo Advanced Combustion Technology (V-ACT), it is designed to deliver superior performance and fuel efficiency. The engine uses precise, highpressure fuel injectors, turbo charger and air-to-air intercooler, and electronic engine controls to optimize machine performance.

Air Filter: 3-stage with precleaner.

Automatic Idling System: Reduces engine speed to idle when the levers and pedals are not activated resulting in less fuel consumption and low cab noise levels.

Engine	Volvo	D13J
Max power at	r/min	1 800
Net, ISO 9249/SAE J1349	kW	283
	hp	385
Gross, ISO 14396/SAE J1995	kW	284
	hp	386
Max torque	Nm	1 928
at engine speed	r/min	1 350
No. of cylinders		6
Displacement	l	12.8
Bore	mm	131
Stroke	mm	158

Electrical system

High-capacity electrical system that is well protected. Waterproof double-lock harness plugs are used to secure corrosion-free connections. The main relays and solenoid valves are shielded to prevent damage. The master switch is standard. Contronics provides advanced monitoring of machine functions and important diagnostic information.

Voltage	V	24
Batteries	V	2 x 12
Battery capacity	Ah	200
Alternator	V/A	28/80

Swing system

The swing system uses an axial piston motors, driving a planetary gearbox for maximum torque. An automatic holding brake and antirebound valve are standard.

Max. slew speed	r/min	9.3
Max. slew torque	kNm	166.3

Travel System

Each track is powered by an automatic two-speed shift travel motor. The track brakes are multi-disc, spring-applied and hydraulic released. The travel motor, brake and planetary gears are well protected within the track frame.

Max. drawbar pull	kN	333.4
Max. travel speed (low)	km/h	3.2
Max. travel speed (high)	km/h	5.2
Gradeability	°	35

Undercarriage

The undercarriage has a robust X-shaped frame. Greased and sealed track chains are standard.

Track shoes		2 x 52
Link pitch	mm	215.9
Shoe width, triple grouser	mm	600 / 600HD* / 700 / 800 / 900
Shoe width, double grouser	mm	600
Bottom rollers		2 x 9
Top rollers		2 x 2
Top rollers (retractable)		2 x 3

* Not HD shoe but HD track link

Sound Level

Sound pressure level in cab according to ISO 6396		
L _{pA}	dB	71
External sound level according to ISO 6395 and EU Noise Directive 2000/14/EC		
L _{WA}	dB	106

Hydraulic system

The new electro-hydraulic system and new MCV (main control valve) use intelligent technology to control on-demand flow for highproductivity, high-digging capacity and excellent fuel consumption.

The following important functions are included in the system for optimum performance:

Summation system: Combines the flow of both hydraulic pumps to ensure quick cycle times and high productivity.

Boom priority: Gives priority to the boom operation for faster raising when loading or performing deep excavations.

Arm priority: Gives priority to the arm operation for faster cycle times in leveling and for increased bucket filling when digging.

Swing priority: Gives priority to swing functions for faster simultaneous operations.

Regeneration system: Prevents cavitation and provides flow to other movements during simultaneous operations for maximum productivity.

Power boost: All digging and lifting forces are increased.

Holding valves: Boom and arm holding valves prevent the digging equipment from creeping.

Main pump, Type 2 x variable displacement axial piston pumps

Maximum flow	l/min	2 x 376
--------------	-------	---------

Pilot pump, Type Gear pump

Maximum flow	l/min	32
--------------	-------	----

Relief value setting pressure

Implement	MPa	32.4/35.3
-----------	-----	-----------

Travel circuit	MPa	32.4
----------------	-----	------

Slew circuit	MPa	25.8
--------------	-----	------

Pilot circuit	MPa	3.9
---------------	-----	-----

Hydraulic Motors

Travel: Variable displacement axial piston motor with mechanical brake.

Slew: Fixed displacement axial piston motor with mechanical brake

Hydraulic Cylinders

Mono boom		2
Bore x Stroke	ø x mm	165 x 1 590
Arm		1
Bore x Stroke	ø x mm	190 x 1 850
Bucket		1
Bore x Stroke	ø x mm	165 x 1 335
ME Bucket		1
Bore x Stroke	ø x mm	175 x 1 335

Service Refill

Fuel tank	l	680
DEF/AdBlue® tank	l	62.5
Hydraulic system, total	l	525
Hydraulic tank	l	270
Engine oil	l	42
Engine coolant	l	60
Slew reduction unit	l	2 x 6
Travel reduction unit	l	2 x 7.5

Cab

The operator's cab has easy access via a wide door opening. The cab is supported on hydraulic dampening mounts to reduce shock and vibration levels. These along with sound absorbing lining provide low noise levels.

The cab has excellent all-round visibility. The front windshield can easily slide up into the ceiling, and the lower front glass can be removed and stored in the side door.

Integrated airconditioning and heating system: The pressurized and filtered cab air is supplied by an automatically controlled fan. The air is distributed throughout the cab from 14 vents.

Ergonomic operator's seat: The adjustable seat and joystick console move independently to accommodate the operator. The seat has nine different adjustments plus a seat belt for the operator's comfort and safety.

Refrigerant of the type R134a is used when this machine is equipped with air conditioning. Contains fluorinated greenhouse gas R134a, Global Warming Potential 1430 CO₂-eq.

Specifications

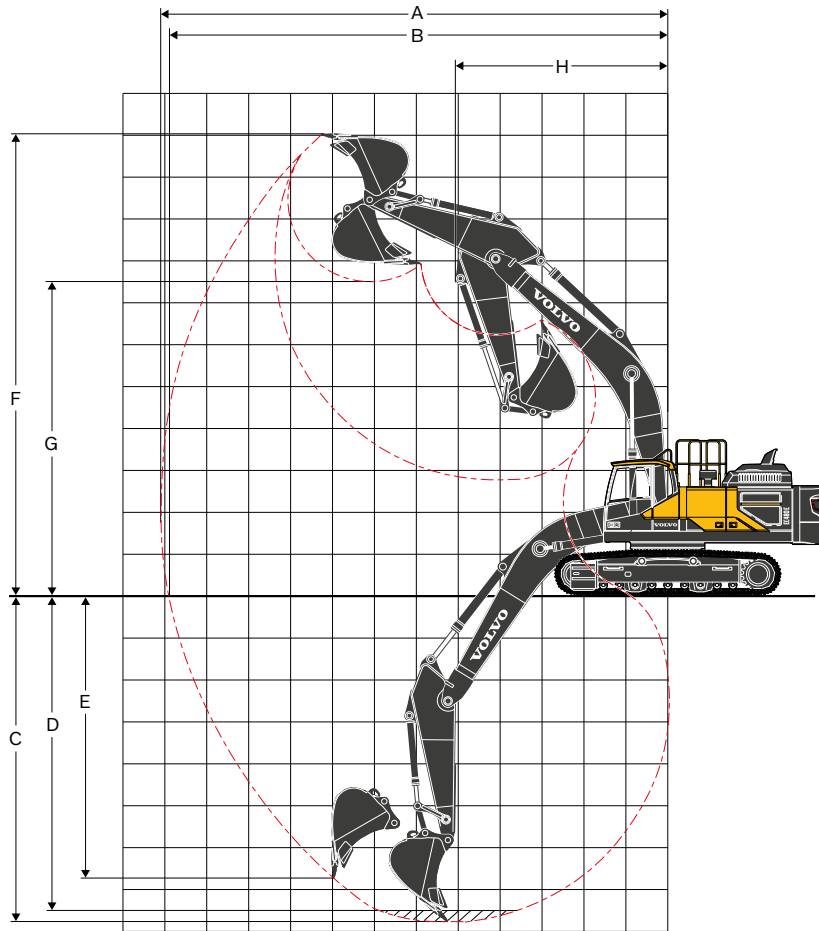

WORKING RANGE

Description	Unit	EC480E *							EC480E, mechanically retractable width **						
Boom	m	6.5 ME			7.0				6.5 ME			7.0			
Arm	m	2.5	3.0	2.55	3.0	3.35	3.9	4.8	2.55	3.0	2.55	3.0	3.35	3.9	4.8
A. Max. digging reach	mm	10 934	11 294	11 453	11 817	12 146	12 645	13 366	10 934	11 294	11 453	11 817	12 146	12 644	13 366
B. Max. digging reach on ground	mm	10 690	11 058	11 221	11 592	11 927	12 434	13 168	10 665	11 034	11 197	11 570	11 905	12 413	13 148
C. Max. digging depth	mm	6 586	7 036	7 028	7 478	7 828	8 378	9 278	6 476	6 926	6 918	7 368	7 718	8 268	9 168
D. Max. digging depth (2.44 m level)	mm	6 418	6 884	6 860	7 325	7 686	8 250	9 167	3 608	6 774	6 750	7 215	7 576	8 139	9 057
E. Max. vertical wall digging depth	mm	5 769	6 160	6 242	6 436	6 774	7 214	7 625	5 659	6 050	6 132	6 326	6 664	7 104	7 515
F. Max. cutting height	mm	10 584	10 580	10 910	10 909	11 064	11 234	11 168	10 694	10 690	11 021	11 019	11 174	11 344	11 278
G. Max. dumping height	mm	6 957	7 015	7 310	7 372	7 526	7 713	7 744	7 067	7 125	7 420	7 482	7 636	7 823	7 854
H. Min. front slew radius	mm	4 758	4 743	5 040	5 135	5 088	5 050	5 100	4 757	4 743	5 043	5 135	5 088	5 050	5 100

Digging forces with direct fit bucket

Breakout force - bucket (Normal/Power boost)	SAE J1179	kN	253	253	230	230	230	230	230	253	253	230	230	230	230
	SAE J1179	kN	275	275	251	251	251	251	251	275	275	251	251	251	251
	ISO 6015	kN	285	285	261	261	261	261	261	285	285	261	261	261	261
	ISO 6015	kN	311	311	284	284	284	284	284	311	311	284	284	284	284
Tearout force - dipper arm (Normal/Power boost)	SAE J1179	kN	225	205	232	211	196	176	160	225	205	232	211	196	176
	SAE J1179	kN	244	224	252	230	215	192	174	244	224	252	230	215	192
	ISO 6015	kN	232	212	239	216	201	179	163	232	212	239	216	201	179
	ISO 6015	kN	253	231	260	235	220	196	178	253	231	260	235	220	196

* FIXED UNDERCARRIAGE, Machine with pin-on bucket

** RETRACTABLE UNDERCARRIAGE, Machine with pin-on bucket

MACHINE WEIGHTS AND GROUND PRESSURE

Description	Shoe width	Operating weight	Ground pressure	Operating weight	Ground pressure
	mm	kg	kPa	kg	kPa
Triple grouser	600	47 961	87.5	49 011	89.4
	700	48 463	75.8	49 513	77.4
	800	48 972	67.0	50 015	68.4
	900	49 476	60.2	50 517	61.4
Triple grouser(HD)	600	48 075	87.7	49 125	89.6
Double grouser	600	48 013	87.6	49 063	89.5

EC480EL with FIXED undercarriage,
 7.0 m boom, 3.35 m arm,
 2 200 kg bucket, 9 750 kg counterweight

EC480EL with RETRACTABLE undercarriage,
 7.0 m boom, 3.35 m arm,
 2 200 kg bucket, 9 750 kg counterweight

BUCKET SELECTION GUIDE

Bucket type		Capacity	Cutting width	Weight	Teeth	EC480EL fixed undercarriage						
						600mm shoe, 9 750kg counterweight						
						6.5 ME			7.0 m Boom			
						L	mm	kg	EA	ME 2.55 m	3.0 m	2.55 m
Direct fit Buckets	General purpose	1 550	1 200	1 763	4	C	C	C	C	C	C	C
		2 100	1 500	2 085	5	C	C	C	C	C	C	C
		2 380	1 650	2 217	5	C	C	C	C	C	C	B
		2 660	1 800	2 350	5	C	C	C	C	C	B	A
		2 840	1 900	2 441	5	C	C	C	C	B	B	A
	3 310	2 150	2 712	6	C	B	B	B	A	X	X	
	Heavy duty	2 100	1 500	2 316	5	D	D	D	D	D	D	C
		2 380	1 650	2 453	5	D	D	D	D	D	C	B
		2 660	1 800	2 606	5	D	D	D	C	C	B	A
		2 840	1 900	2 698	5	D	C	C	B	B	A	X
3 030		2 000	2 861	5	D	C	C	B	B	A	X	

Bucket type		Capacity	Cutting width	Weight	Teeth	EC480EL retractable undercarriage						
						600mm shoe, 9 750kg counterweight						
						6.5 ME			7.0 m Boom			
						L	mm	kg	EA	ME 2.55 m	3.0 m	2.55 m
Direct fit Buckets	General purpose	1 550	1 200	1 763	4	C	C	C	C	C	C	C
		2 100	1 500	2 085	5	C	C	C	C	C	C	C
		2 380	1 650	2 217	5	C	C	C	C	C	C	C
		2 660	1 800	2 350	5	C	C	C	C	C	C	B
		2 840	1 900	2 441	5	C	C	C	C	B	B	B
	3 310	2 150	2 712	6	C	C	B	B	B	A	X	
	Heavy duty	2 100	1 500	2 316	5	D	D	D	D	D	D	D
		2 380	1 650	2 453	5	D	D	D	D	D	D	B
		2 660	1 800	2 606	5	D	D	D	D	D	C	B
		2 840	1 900	2 698	5	D	D	D	C	C	B	A
3 030		2 000	2 861	5	D	C	D	C	B	B	X	

Please consult with your Volvo dealer for the proper match of buckets and attachments to suit the application.
 The recommendations are given as a guide only, based on typical operation conditions.
 Bucket capacity based on ISO 7451, heaped material with a 1:1 angle of repose.

X : Not recommended
Maximum material density
 A: 1 200 - 1 300 kg/m³ Coal, Caliche, Shale
 B: 1 400 - 1 600 kg/m³ Wet earth and clay, Limestone, Sandstone
 C: 1 700 - 1 800 kg/m³ Granite, Wet sand, Well blasted rock
 D: > 1 900 kg/m³ Wet mud, Iron ore

Specifications

LIFTING CAPACITY EC480EL

Lifting capacity at the arm end without bucket.

For lifting capacity including bucket, simply subtract actual weight of the direct fit bucket or the bucket with quick coupler from the following values.

	Lifting hook related to ground level	1.5 m		3.0 m		4.5 m		6.0 m		7.5 m		9.0 m		10.5 m		Max. reach				
		Along UC	Across UC	Along UC	Across UC	Along UC	Across UC	Along UC	Across UC	Along UC	Across UC	Along UC	Across UC	Along UC	Across UC	Along UC	Across UC	m		
Boom: 6.5m ME Arm: 2.55m Shoe: 600mm CWT: 9 750kg	7.5 m	kg															*12 280	11 450	7.3	
	6 m	kg							*13 270	*13 270	*12 200	10 810						*12 030	9 420	8.2
	4.5 m	kg						*19 800	*19 800	*15 110	14 650	*12 950	10 530					*12 030	8 370	8.7
	3 m	kg						*23 500	20 910	*17 170	13 950	*13 970	10 180					12 330	7 870	8.9
	1.5 m	kg						*17 080	*17 080	*18 730	13 420	*14 840	9 880					12 210	7 750	8.9
	0 m	kg						*25 160	19 990	*19 360	13 150	*15 240	9 700					12 670	8 010	8.7
	-1.5 m	kg			*18 530	*18 530	*24 830	20 080	*18 920	13 110	*14 810	9 690						*13 250	8 760	8.1
	-3 m	kg			*28 560	*28 560	*22 190	20 380	*17 110	13 290								*13 350	10 410	7.2
	-4.5 m	kg					*17 080	*17 080												5.8
Boom: 6.5m ME Arm: 3.0m Shoe: 600mm CWT: 9 750kg	7.5 m	kg									*11 170	10 930					*10 570	10 420	7.7	
	6 m	kg									*11 350	10 810					*10 270	8 690	8.5	
	4.5 m	kg						*18 090	*18 090	*14 130	*14 130	*12 210	10 480	*11 300	7 860		*10 360	7 770	9.1	
	3 m	kg						*22 630	21 060	*16 280	13 910	*13 320	10 090	*11 730	7 690		*10 750	7 300	9.3	
	1.5 m	kg						*24 490	20 010	*18 050	13 290	*14 320	9 740	11 940	7 530		11 370	7 180	9.3	
	0 m	kg						*26 010	19 660	*18 970	12 930	*14 910	9 510	11 840	7 430		11 750	7 380	9.	
	-1.5 m	kg			*19 130	*19 130	*25 170	19 660	*18 870	12 820	*14 800	9 440						*12 570	8 000	8.5
	-3 m	kg			*30 950	*30 950	*23 000	19 910	*17 550	12 940	*13 360	9 580						*12 870	9 330	7.7
	-4.5 m	kg					*18 790	*18 790	*13 950	13 380								*12 730	12 430	6.3
Boom: 7.0m Arm: 2.55m Shoe: 600mm CWT: 9 750kg	9.0 m	kg															*11 710	*11 710	6.6	
	7.5 m	kg										*11 170	10 920				*11 270	9 980	7.9	
	6 m	kg										*12 920	*12 920	*11 540	10 740			*11 180	8 410	8.7
	4.5 m	kg								*14 950	14 350	*12 500	10 380	*11 320	7 880		*11 260	7 570	9.2	
	3 m	kg								*17 080	13 600	*13 610	10 000	*11 790	7 710		11 220	7 150	9.5	
	1.5 m	kg								*18 570	13 090	*14 540	9 690	11 950	7 550		11 110	7 050	9.5	
	0 m	kg								*19 110	12 860	*15 020	9 510	11 860	7 470		11 490	7 250	9.2	
	-1.5 m	kg							*24 260	19 790	*18 750	12 850	*14 830	9 480				*12 310	7 850	8.7
	-3 m	kg			*27 060	*27 060	*22 120	20 070	*17 360	13 020	*13 500	9 640						*12 490	9 110	7.9
-4.5 m	kg							*18 270	*18 270	*14 090	13 450						*12 200	11 940	6.6	

Notes: 1. Machine in "Fine Mode-F" (Power Boost) for lifting capacities. 2. The above loads are in compliance with SAE J1097 and ISO 10567 Hydraulic Excavator Lifting Capacity Standards. 3. Rated loads do not exceed 87% of hydraulic lifting capacity or 75% of tipping load. 4. Rated loads marked with an asterisk (*) are limited by hydraulic capacity rather than tipping load.

LIFTING CAPACITY EC480EL

Lifting capacity at the arm end without bucket.

For lifting capacity including bucket, simply subtract actual weight of the direct fit bucket or the bucket with quick coupler from the following values.

	Lifting hook related to ground level	1.5 m		3.0 m		4.5 m		6.0 m		7.5 m		9.0 m		10.5 m		Max. reach			
		Along UC	Across UC	Along UC	Across UC	Along UC	Across UC	Along UC	Across UC	Along UC	Across UC	Along UC	Across UC	Along UC	Across UC	Along UC	Across UC	m	
Boom: 7.0m Arm: 3.0m Shoe: 600mm CWT: 9 750kg	9.0 m	kg															*10 650	*10 650	7.2
	7.5 m	kg								*10 270	*10 270						*10 380	9 150	8.3
	6 m	kg								*10 800	10 740	*10 350	7 970				*10 360	7 790	9.1
	4.5 m	kg					*18 750	*18 750	*14 010	*14 010	*11 810	10 350	*10 690	7 830			*10 490	7 040	9.6
	3 m	kg							*16 220	13 580	*13 000	9 920	*11 270	7 610			10 500	6 650	9.8
	1.5 m	kg							*17 920	12 970	*14 040	9 560	11 820	7 420			10 390	6 540	9.8
	0 m	kg					*17 740	*17 740	*18 750	12 660	*14 680	9 330	11 680	7 290			10 690	6 700	9.6
	-1.5 m	kg			*13 630	*13 630	*24 700	19 360	*18 680	12 580	*14 720	9 250	11 680	7 290			11 520	7 200	9.1
	-3 m	kg			*25 270	*25 270	*22 860	19 610	*17 650	12 700	*13 860	9 350					*11 990	8 240	8.3
-4.5 m	kg					*19 560	*19 560	*15 150	13 050							*12 050	10 440	7.1	
Boom: 7.0m Arm: 3.35m Shoe: 600mm CWT: 9 750kg	9.0 m	kg								*10 020	*10 020						*10 080	*10 080	7.6
	7.5 m	kg								*9 760	*9 760						*9 470	8 580	8.7
	6 m	kg								*10 360	*10 360	*9 900	8 090				*9 270	7 400	9.5
	4.5 m	kg					*17 590	*17 590	*13 440	*13 440	*11 430	10 470	*10 360	7 910			*9 340	6 720	9.9
	3 m	kg					*22 320	20 680	*15 730	13 760	*12 680	10 020	*11 020	7 680			*9 670	6 370	10.2
	1.5 m	kg					*15 350	*15 350	*17 590	13 100	*13 820	9 630	*11 660	7 460			9 920	6 260	10.2
	0 m	kg					*18 910	*18 910	*18 640	12 720	*14 580	9 370	11 700	7 310			10 180	6 400	9.9
	-1.5 m	kg			*13 700	*13 700	*25 160	19 320	*18 790	12 590	*14 780	9 260	11 650	7 260			10 900	6 830	9.4
	-3 m	kg			*23 340	*23 340	*23 580	19 530	*18 020	12 660	*14 180	9 300					*11 610	7 720	8.7
-4.5 m	kg			*27 470	*27 470	*20 660	19 960	*15 940	12 950	*11 940	9 600					*11 790	9 530	7.5	
Boom: 7.0m Arm: 3.9m Shoe: 600mm CWT: 9 750kg	9 m	kg															*8 060	*8 060	8.3
	7.5 m	kg										*9 070	8 310				*7 630	*7 630	9.3
	6 m	kg									*9 620	*9 620	*9 230	8 220			*7 490	6 830	10.
	4.5 m	kg							*12 430	*12 430	*10 750	10 610	*9 800	8 000			*7 550	6 250	10.4
	3 m	kg					*20 560	*20 560	*14 830	14 000	*12 090	10 140	*10 550	7 740	*9 440	6 080	*7 800	5 930	10.7
	1.5 m	kg					*20 860	19 940	*16 920	13 250	*13 350	9 710	*11 300	7 490	9 450	5 960	*8 260	5 830	10.7
	0 m	kg					*20 810	19 360	*18 280	12 780	*14 280	9 390	11 690	7 300			*9 000	5 930	10.4
	-1.5 m	kg	*9 630	*9 630	*13 700	*13 700	*25 520	19 230	*18 780	12 560	*14 710	9 220	11 590	7 200			10 030	6 280	10.
	-3 m	kg	*16 090	*16 090	*21 130	*21 130	*24 410	19 350	*18 370	12 560	*14 450	9 210	*11 540	7 240			*11 010	6 990	9.3
-4.5 m	kg			*30 400	*30 400	*22 040	19 690	*16 850	12 750	*13 070	9 380					*11 330	8 370	8.2	
-6 m	kg					*17 660	*17 660	*13 260	13 240							*11 290	*11 290	6.7	
Boom: 7.0m Arm: 4.8m Shoe: 600mm CWT: 9 750kg	9 m	kg										*7 880	*7 880				*7 290	*7 290	9.2
	7.5 m	kg										*7 720	*7 720				*7 020	6 860	10.1
	6 m	kg										*8 080	*8 080	*8 090	6 370		*6 950	6 060	10.8
	4.5 m	kg								*9 440	*9 440	*8 760	8 090	*8 380	6 250	*7 040	5 570	11.2	
	3 m	kg					*17 390	*17 390	*13 050	*13 050	*10 870	10 270	*9 610	7 770	*8 850	6 080	*7 300	5 300	11.4
	1.5 m	kg					*21 700	20 380	*15 450	13 420	*12 310	9 750	*10 500	7 460	*9 360	5 900	*7 740	5 190	11.4
	0 m	kg					*24 290	19 350	*17 250	12 760	*13 490	9 340	*11 250	7 210	9 240	5 750	*8 420	5 240	11.2
	-1.5 m	kg	*9 300	*9 300	*13 830	*13 830	*25 250	18 930	*18 260	12 390	*14 250	9 070	11 430	7 030	9 160	5 670	8 860	5 490	10.8
	-3 m	kg	*14 260	*14 260	*19 340	*19 340	*24 960	18 870	*18 420	12 260	*14 430	8 960	11 360	6 980			9 690	6 000	10.1
-4.5 m	kg	*19 970	*19 970	*26 530	*26 530	*23 480	19 070	*17 630	12 340	*13 820	9 010	*10 870	7 080			*10 600	6 950	9.1	
-6 m	kg			*28 670	*28 670	*20 450	19 540	*15 490	12 640	*11 730	9 300					*11 050	8 890	7.8	

Notes: 1. Machine in "Fine Mode-F" (Power Boost) for lifting capacities. 2. The above loads are in compliance with SAE J1097 and ISO 10567 Hydraulic Excavator Lifting Capacity Standards. 3. Rated loads do not exceed 87% of hydraulic lifting capacity or 75% of tipping load. 4. Rated loads marked with an asterisk (*) are limited by hydraulic capacity rather than tipping load.

Specifications

LIFTING CAPACITY EC480E mechanically retractable width

Lifting capacity at the arm end without bucket.

For lifting capacity including bucket, simply subtract actual weight of the direct fit bucket or the bucket with quick coupler from the following values.

	Lifting hook related to ground level	1.5 m		3.0 m		4.5 m		6.0 m		7.5 m		9.0 m		10.5 m		Max. reach			
		Along UC	Across UC	Along UC	Across UC	Along UC	Across UC	Along UC	Across UC	Along UC	Across UC	Along UC	Across UC	Along UC	Across UC	Along UC	Across UC	m	
Boom: 6.5m ME Arm: 2.55m Shoe: 600mm CWT: 9 750kg	7.5 m	kg															*12 280	11 680	7.3
	6 m	kg						*13 270	*13 270	*12 200	11 030						*12 030	9 620	8.2
	4.5 m	kg					*19 800	*19 800	*15 110	14 950	*12 950	10 750					*12 030	8 560	8.7
	3 m	kg					*23 500	21 350	*17 170	14 250	*13 970	10 410					*12 360	8 050	8.9
	1.5 m	kg					*17 080	*17 080	*18 730	13 720	*14 840	10 110					12 510	7 930	8.9
	0 m	kg					*25 160	20 440	*19 360	13 450	*15 240	9 930					*12 950	8 200	8.7
	-1.5 m	kg			*18 530	*18 530	*24 830	20 530	*18 920	13 410	*14 810	9 910					*13 250	8 970	8.1
	-3 m	kg			*28 560	*28 560	*22 190	20 820	*17 110	13 590							*13 350	10 650	7.2
	-4.5 m	kg					*17 080	*17 080											
Boom: 6.5m ME Arm: 3.0m Shoe: 600mm CWT: 9 750kg	7.5 m	kg								*11 170	11 160						*10 570	*10 570	7.7
	6 m	kg								*11 350	11 030						*10 270	8 880	8.5
	4.5 m	kg					*18 090	*18 090	*14 130	*14 130	*12 210	10 710	*11 300	8 040			*10 360	7 950	9.1
	3 m	kg					*22 630	21 510	*16 280	14 210	*13 320	10 310	*11 730	7 870			*10 750	7 480	9.3
	1.5 m	kg					*24 490	20 460	*18 050	13 590	*14 320	9 960	*12 160	7 710			*11 540	7 350	9.3
	0 m	kg					*26 010	20 110	*18 970	13 230	*14 910	9 730	12 140	7 610			12 050	7 560	9.
	-1.5 m	kg			*19 130	*19 130	*25 170	20 110	*18 870	13 120	*14 800	9 660					*12 570	8 190	8.5
	-3 m	kg			*30 950	*30 950	*23 000	20 360	*17 550	13 240	*13 360	9 810					*12 870	9 550	7.7
	-4.5 m	kg					*18 790	*18 790	*13 950	13 680							*12 730	12 710	6.3
Boom: 7.0m Arm: 2.55m Shoe: 600mm CWT: 9 750kg	9.0 m	kg															*11 710	*11 710	6.6
	7.5 m	kg								*11 170	11 170						*11 270	10 720	7.9
	6 m	kg							*12 920	*12 920	*11 540	11 540					*11 180	9 050	8.7
	4.5 m	kg							*14 950	*14 950	*12 500	11 180	*11 320	8 490			*11 260	8 160	9.2
	3 m	kg							*17 080	14 720	*13 610	10 790	*11 790	8 320			*11 450	7 710	9.5
	1.5 m	kg							*18 570	14 200	*14 540	10 470	*12 230	8 160			11 400	7 610	9.5
	0 m	kg							*19 110	13 970	*15 020	10 290	12 160	8 080			11 780	7 840	9.2
	-1.5 m	kg					*24 260	21 630	*18 750	13 950	*14 830	10 260					*12 310	8 490	8.7
	-3 m	kg			*27 060	*27 060	*22 120	21 920	*17 360	14 130	*13 500	10 420					*12 490	9 850	7.9
-4.5 m	kg					*18 270	*18 270	*14 090	*14 090							*12 200	*12 200	6.6	
Boom: 7.0m Arm: 3.0m Shoe: 600mm CWT: 9 750kg	9.0 m	kg															*10 650	*10 650	7.2
	7.5 m	kg								*10 270	*10 270						*10 380	9 830	8.3
	6 m	kg								*10 800	*10 800	*10 350	8 590				*10 360	8 390	9.1
	4.5 m	kg					*18 750	*18 750	*14 010	*14 010	*11 810	11 150	*10 690	8 440			*10 490	7 600	9.6
	3 m	kg							*16 220	14 700	*13 000	10 710	*11 270	8 220			*10 700	7 190	9.8
	1.5 m	kg							*17 920	14 080	*14 040	10 350	*11 830	8 020			10 660	7 080	9.8
	0 m	kg					*17 740	*17 740	*18 750	13 760	*14 680	10 110	11 990	7 900			10 970	7 260	9.6
	-1.5 m	kg			*13 630	*13 630	*24 700	21 190	*18 680	13 680	*14 720	10 030	*11 860	7 900			*11 680	7 800	9.1
	-3 m	kg			*25 270	*25 270	*22 860	21 450	*17 650	13 810	*13 860	10 130					*11 990	8 920	8.3
-4.5 m	kg					*19 560	*19 560	*15 150	14 160							*12 050	11 300	7.1	

Notes: 1. Machine in "Fine Mode-F" (Power Boost) for lifting capacities. 2. The above loads are in compliance with SAE J1097 and ISO 10567 Hydraulic Excavator Lifting Capacity Standards. 3. Rated loads do not exceed 87% of hydraulic lifting capacity or 75% of tipping load. 4. Rated loads marked with an asterisk (*) are limited by hydraulic capacity rather than tipping load.

LIFTING CAPACITY EC480E mechanically retractable width

Lifting capacity at the arm end without bucket.

For lifting capacity including bucket, simply subtract actual weight of the direct fit bucket or the bucket with quick coupler from the following values.

	Lifting hook related to ground level	1.5 m		3.0 m		4.5 m		6.0 m		7.5 m		9.0 m		10.5 m		Max. reach			
		Along UC	Across UC	Along UC	Across UC	Along UC	Across UC	Along UC	Across UC	Along UC	Across UC	Along UC	Across UC	Along UC	Across UC	Along UC	Across UC	m	
Boom: 7.0m Arm: 3.35m Shoe: 600mm CWT: 9 750kg	9.0 m	kg									*10 020	*10 020				*10 080	*10 080	7.6	
	7.5 m	kg									*9 760	*9 760				*9 470	9 230	8.7	
	6 m	kg									*10 360	*10 360	*9 900	8 700		*9 270	7 970	9.5	
	4.5 m	kg					*17 590	*17 590	*13 440	*13 440	*11 430	11 260	*10 360	8 520		*9 340	7 250	9.9	
	3 m	kg					*22 320	*22 320	*15 730	14 880	*12 680	10 810	*11 020	8 280		*9 670	6 880	10.2	
	1.5 m	kg					*15 350	*15 350	*17 590	14 210	*13 820	10 420	*11 660	8 060		10 180	6 780	10.2	
	0 m	kg					*18 910	*18 910	*18 640	13 830	*14 580	10 150	12 000	7 910		10 450	6 930	9.9	
	-1.5 m	kg			*13 700	*13 700	*25 160	21 160	*18 790	13 700	*14 780	10 040	11 950	7 870		11 190	7 400	9.4	
	-3 m	kg			*23 340	*23 340	*23 580	21 370	*18 020	13 770	*14 180	10 090				*11 610	8 350	8.7	
-4.5 m	kg			*27 470	*27 470	*20 660	*20 660	*15 940	14 050	*11 940	10 390				*11 790	10 310	7.5		
Boom: 7.0m Arm: 3.9m Shoe: 600mm CWT: 9 750kg	9 m	kg														*8 060	*8 060	8.3	
	7.5 m	kg											*9 070	8 920		*7 630	*7 630	9.3	
	6 m	kg									*9 620	*9 620	*9 230	8 830		*7 490	7 360	10.	
	4.5 m	kg							*12 430	*12 430	*10 750	*10 750	*9 800	8 610		*7 550	6 750	10.4	
	3 m	kg					*20 560	*20 560	*14 830	*14 830	*12 090	10 930	*10 550	8 350	*9 440	6 580	*7 800	6 420	10.7
	1.5 m	kg					*20 860	*20 860	*16 920	14 370	*13 350	10 500	*11 300	8 100	9 700	6 460	*8 260	6 310	10.7
	0 m	kg					*20 810	*20 810	*18 280	13 880	*14 280	10 180	*11 860	7 900		*9 000	6 430	10.4	
	-1.5 m	kg	*9 630	*9 630	*13 700	*13 700	*25 520	21 060	*18 780	13 660	*14 710	10 000	11 890	7 810		*10 190	6 810	10.	
	-3 m	kg	*16 090	*16 090	*21 130	*21 130	*24 410	21 180	*18 370	13 660	*14 450	9 990	*11 540	7 850		*11 010	7 570	9.3	
-4.5 m	kg			*30 400	*30 400	*22 040	21 530	*16 850	13 860	*13 070	10 170				*11 330	9 060	8.2		
-6 m	kg					*17 660	*17 660	*13 260	*13 260						*11 290	*11 290	6.7		
Boom: 7.0m Arm: 4.8m Shoe: 600mm CWT: 9 750kg	9 m	kg											*7 880	*7 880		*7 290	*7 290	9.2	
	7.5 m	kg											*7 720	*7 720		*7 020	*7 020	10.1	
	6 m	kg											*8 080	*8 080	*8 090	6 870	*6 950	6 540	10.8
	4.5 m	kg									*9 440	*9 440	*8 760	8 700	*8 380	6 740	*7 040	6 030	11.2
	3 m	kg					*17 390	*17 390	*13 050	*13 050	*10 870	*10 870	*9 610	8 390	*8 850	6 570	*7 300	5 740	11.4
	1.5 m	kg					*21 700	*21 700	*15 450	14 540	*12 310	10 540	*10 500	8 070	*9 360	6 390	*7 740	5 630	11.4
	0 m	kg					*24 290	21 190	*17 250	13 870	*13 490	10 120	*11 250	7 810	9 490	6 240	*8 420	5 700	11.2
	-1.5 m	kg	*9 300	*9 300	*13 830	*13 830	*25 250	20 760	*18 260	13 490	*14 250	9 850	*11 720	7 640	9 400	6 160	9 100	5 970	10.8
	-3 m	kg	*14 260	*14 260	*19 340	*19 340	*24 960	20 700	*18 420	13 360	*14 430	9 740	11 670	7 580			9 950	6 520	10.1
-4.5 m	kg	*19 970	*19 970	*26 530	*26 530	*23 480	20 910	*17 630	13 440	*13 820	9 800	*10 870	7 690			*10 600	7 550	9.1	
-6 m	kg			*28 670	*28 670	*20 450	*20 450	*15 490	13 750	*11 730	10 090				*11 050	9 640	7.8		

Notes: 1. Machine in "Fine Mode-F" (Power Boost) for lifting capacities. 2. The above loads are in compliance with SAE J1097 and ISO 10567 Hydraulic Excavator Lifting Capacity Standards. 3. Rated loads do not exceed 87% of hydraulic lifting capacity or 75% of tipping load. 4. Rated loads marked with an asterisk (*) are limited by hydraulic capacity rather than tipping load.

Equipment

STANDARD EQUIPMENT

Engine

Turbocharged, 4 stroke diesel engine with water cooling, direct injection and charged air cooler that meets EU Stage V requirements

Air filter with indicator

Air intake heater

Cyclone pre-cleaner

Electric engine shut-off

Fuel filter and water separator

Fuel filler pump: 50 l/min, with automatic shut-off

Alternator, 80 A

Electric / Electronic control system

Contronics

Advanced mode control system

Self-diagnostic system

Machine status indication

Engine speed sensing power control

Automatic idling system

One-touch power boost

Safety stop/start function

Adjustable LCD color monitor

Master electrical disconnect switch

Engine restart prevention circuit

High-capacity halogen lights:

Frame-mounted 2

Boom-mounted 2

Batteries, 2 x 12 V / 200 Ah

Start motor, 24 V / 7 kW

Frame

Access way with handrail

Tool storage area

Punched metal anti-slip plates

Undercover (heavy-duty)

Undercarriage

Undercover (heavy-duty)

Hydraulic track adjusters

Greased and sealed track link

Track Guard

Hydraulic system

Hose rupture valve: boom

Overload warning device

Automatic sensing hydraulic system

2-pump flow bucket circuit

Summation system

Boom priority

Arm priority

Swing priority

Boom, arm and bucket regeneration valves

Swing anti-rebound valves

Boom and arm holding valves

Multi-stage filtering system

Cylinder cushioning

Cylinder contamination seals

Auxiliary hydraulic valve

Automatic two-speed travel motors

Hydraulic oil, ISO VG 46

STANDARD EQUIPMENT

Cab and interior

ROPS (ISO12117-2) certified cab

Silicon oil and rubber mounts with spring

Travel pedals and hand levers

Adjustable operator seat and joystick control console

Control joysticks with 4 switches each

Heater & air-conditioner, automatic

Flexible antenna

Radio with MP3 & USB Jack with bluetooth

Hydraulic safety lock lever

Cab, all-weather sound suppressed, includes:

Cup holders

Door locks

Tinted glass

Floor mat

Horn

Large storage area

Pull-up type front window

Removable lower windshield

Seat belt

Safety glass

Sun screens, front, roof, rear

Rain shield

Windshield wiper with intermittent feature

Rear view camera

Master key

Track shoes

700 mm with triple grousers

Digging Equipment

Boom: 7.0 m HD

Arm: 3.35 m HD

Manual centralized lubrication

OPTIONAL EQUIPMENT

Engine

Block heater: 120 V, 240 V

Oil bath pre-cleaner

Diesel coolant heater, 10 kW

Water separator with heater

Auto engine shutdown

Electric

Extra work lights: Halogen or LED

Cab-mounted 3

Boom-mounted 2

Counterweight-mounted 1

Travel alarm

Anti-theft system

Rotating warning beacon

Frame

Hydraulic removable counterweight

OPTIONAL EQUIPMENT

Undercarriage

- Full track guard
- Mechanically retractable width track gauge

Hydraulic system

- Hose rupture valve: arm
- Boom float function
- Hydraulic piping:
 - Work tool management system
 - (up to 20 programmable memories)
- Hammer & shear, 1 and 2 pump flow
- Hammer & shear:
 - variable flow and pressure pre-setting
- Additional return filter
- Slope & rotator
- Grapple
- Oil leak (drain) line
- Quick coupler piping
- Volvo hydraulic quick coupler S3
- Volvo hydraulic quick coupler VQC-HU
- Volvo hydraulic quick coupler DR48
- Hydraulic oil, ISO VG 32
- Hydraulic oil, ISO VG 46
- Hydraulic oil, ISO VG 68
- Hydraulic oil, biodegradable 46
- Hydraulic oil, longlife oil 32
- Hydraulic oil, longlife oil 46
- Hydraulic oil, longlife oil 68

OPTIONAL EQUIPMENT

Cab and interior

- Fabric seat with heater
- Fabric seat with heater and air suspension
- Pilot control pattern change
- Opening top hatch
- Falling object guard (FOG)
 - Frame-mounted
 - Cab-mounted
- Cab-mounted falling object protective structure (FOPS)
- Smoker kit (ashtray and lighter)
- Safety net for front window
- Lower wiper with intermittent control
- Side view camera
- Anti-vandalism kit
- Specific key

Track shoes

- Track shoes 600/700/800/900 mm with triple grousers
- Track shoes 600 mm with triple grousers and HD links
- Track shoes 600 mm with double grousers

Digging Equipment

- Boom: 6,5 m ME
- Arm: 2.55 m, 3.0m, 3.9 m, 4.8 m
- Linkage with lifting eye

Service

- Tool kit, daily maintenance
- Tool kit, full scale
- Automatic lubrication system
- Air compressor

SELECTION OF VOLVO OPTIONAL EQUIPMENT

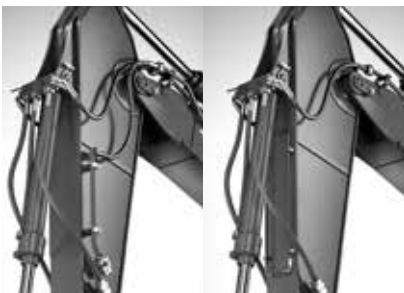
**Auxiliary hydraulics,
Breaker / Shear, Tilt / Rotator****Side-view camera****LED Lights****Air compressor****Retractable undercarriage****Removable counterweight**

Not all products are available in all markets. Under our policy of continuous improvement, we reserve the right to change specifications and design without prior notice. The illustrations do not necessarily show the standard version of the machine.

VOLVO

Volvo Construction Equipment

volvo.com