



Volvo EC700C

High reach demolition* & digging front

*** Max. working height 35 m
tool weight 2500 kg**



Digging front bent

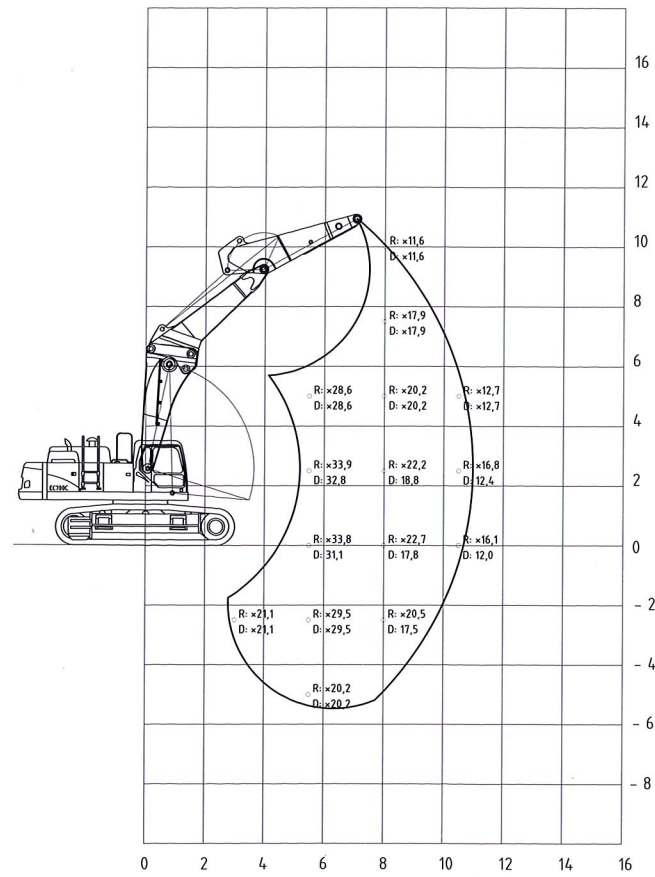

Digging front + boom extension/adapter - A

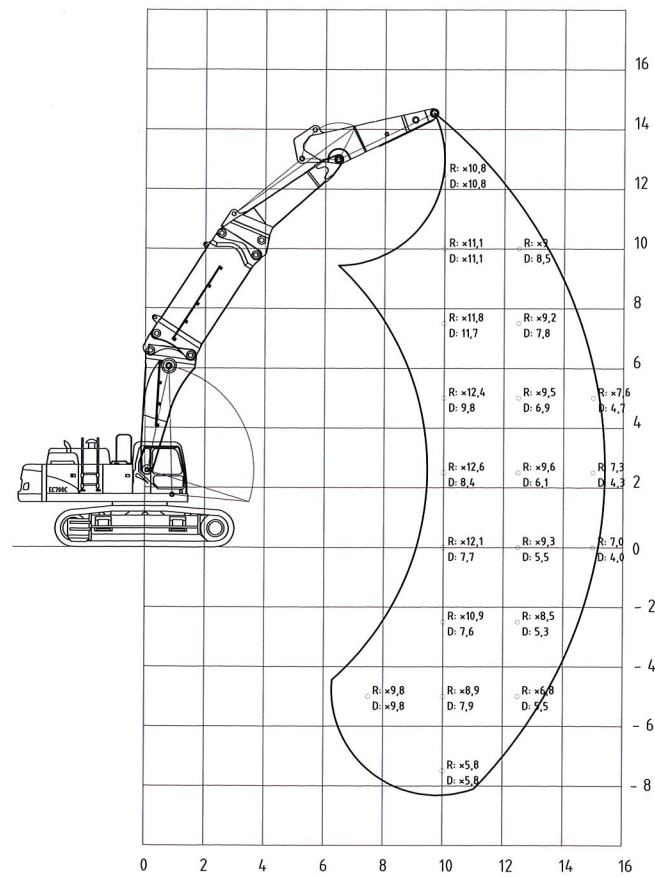

Digging front + boom extension/adapter - D

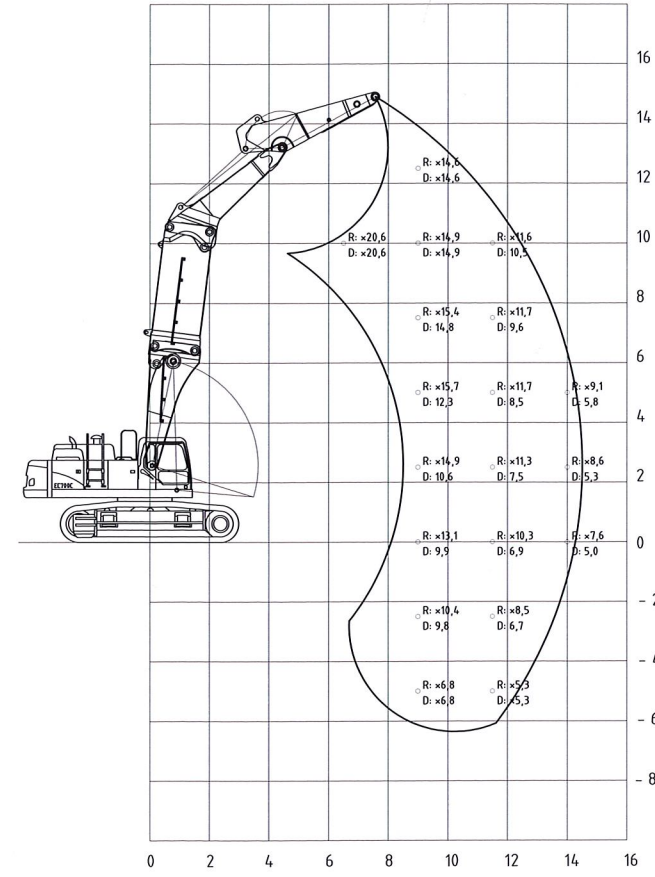

Digging front + boom extension/adapter - E

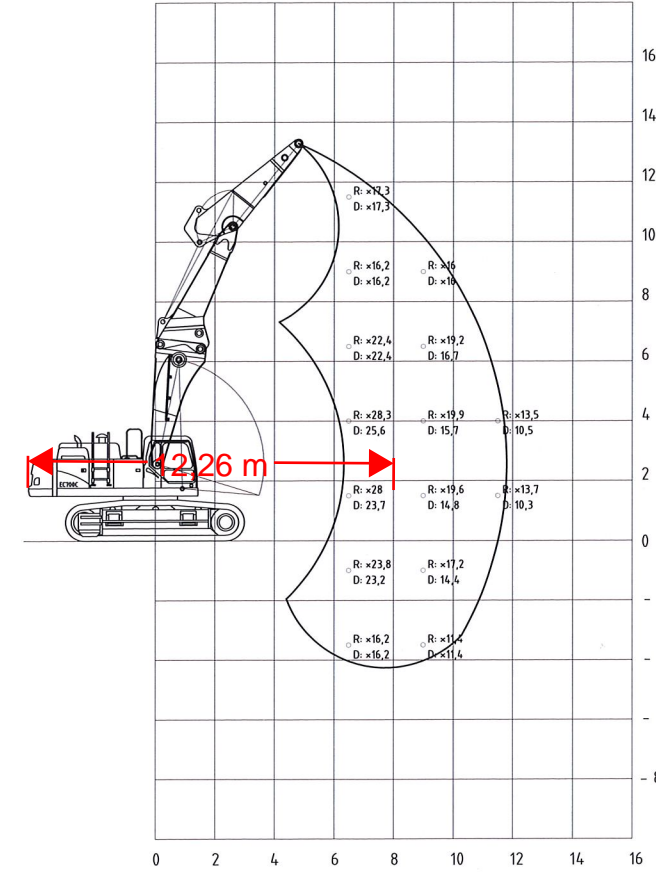

Digging front + boom extension/adapter - B

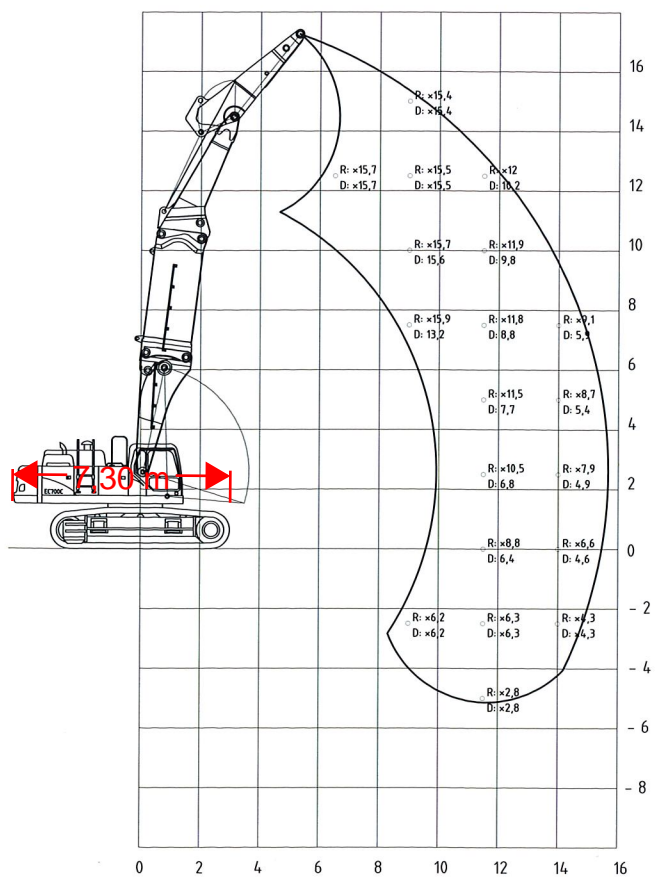

Digging front + boom extension/adapter - C

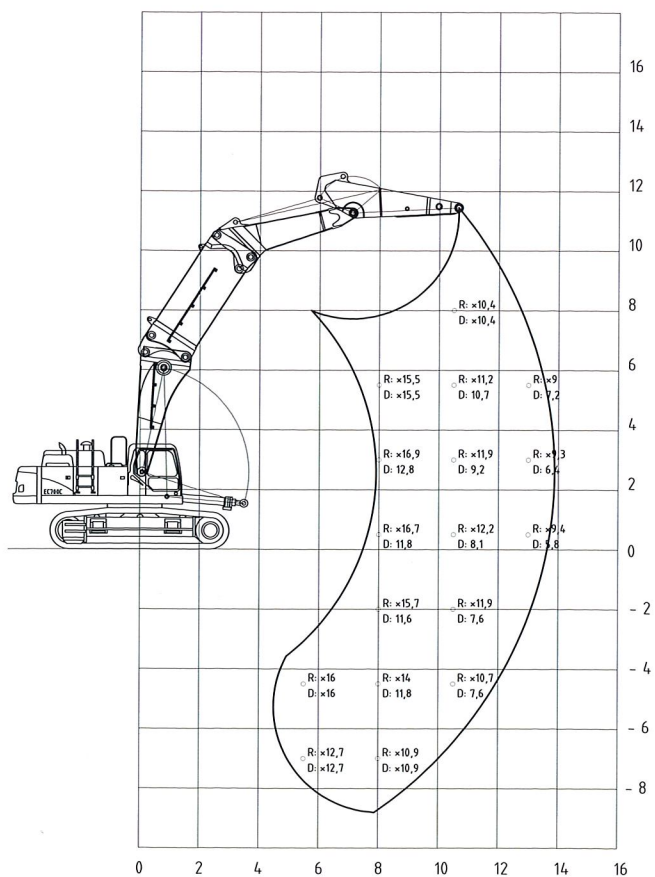

HRD front - Max. tool weight 2,5T

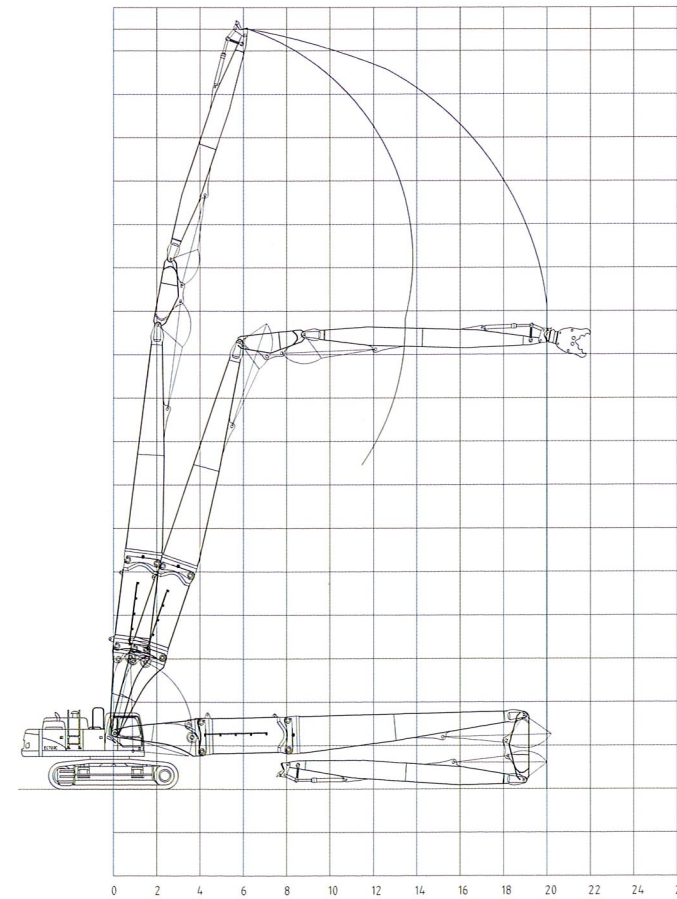

HRD front - Max. tool weight 3,5T

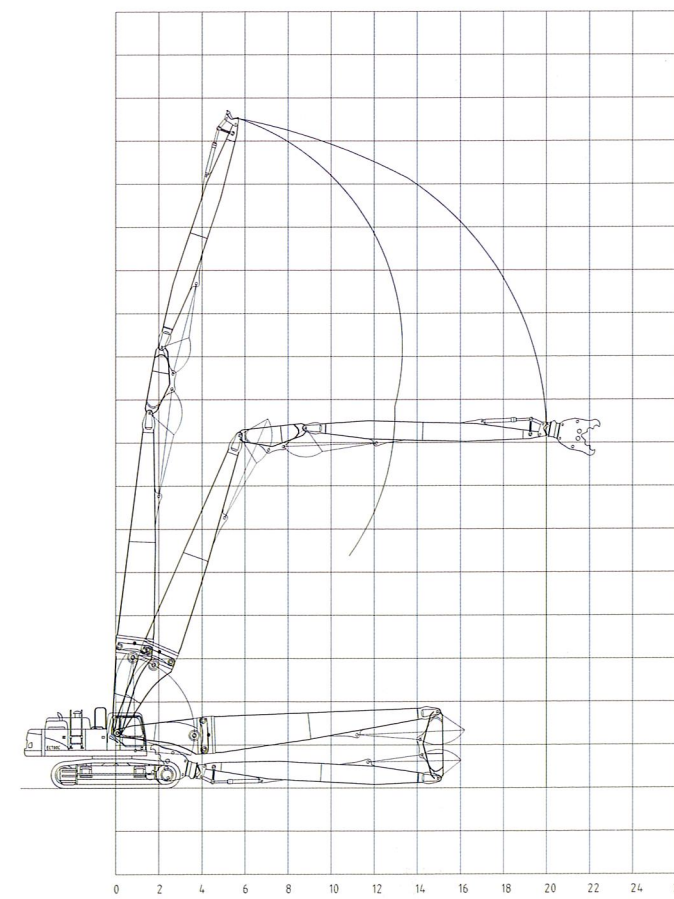

The above loads are according to the hydraulic excavator lift capacity ratings standard ISO/DIS 10567, they do not exceed 87% of hydraulic lifting capacity

or 75% of tipping capacity. Weight of all lifting accessories must be deducted from the above lifting capacities.

Tiltable Cab

For maximum visibility during demolition jobs



- Tilting angle 30°
- Emergency lowering valves inside and outside the cab
- Two (2) tilting cylinders with safety valves
- Operation by joy-sticks and safety selection switch

Additional counterweight (2 sections)

For maximum stability and lifting capacity for each application



- Sandwich type fixed integrated between engine and original counterweight 6 ton
- Removable part on-top mounted 3 ton

Boom quick coupler

For maximum flexibility and utilization

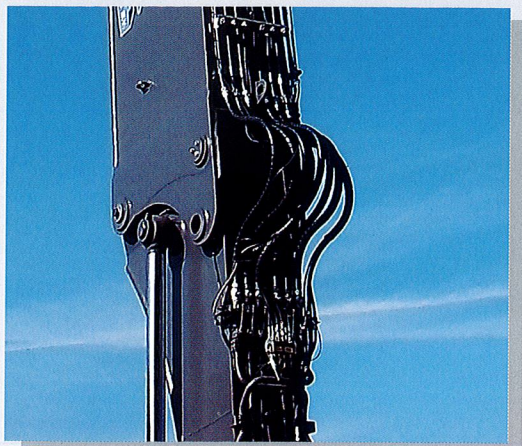

- Hydraulically operated
- Integrated quick coupler cylinder in base boom
- Unique high durability design to avoid stress on cylinder
- 2 positions; bent and straight

Demolition stability monitor

For maximum safety during (high reach) demolition jobs



- Monitoring of machine in all planes
- Warning if stability is compromised
- Multiple tools storage
- "Drop zone" warning
- Backward stability
- Multiple boom layout storage

Hydraulic piping

For operating of cylinders and work tools

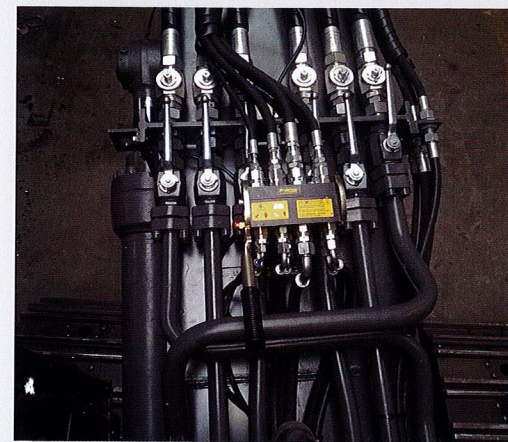

- High quality connections with flair technology
- Type of couplings, quick couplers or connections according to customer's requirements.

Boom extension adapter

For additional working height and/or reach

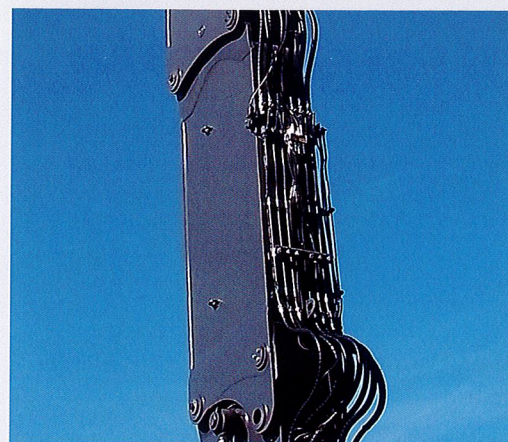

- Length 4m
- Quick coupler for HRD boom and digging boom
- Hydraulically operated quick coupler, optional

FOPS Cabine protection

For maximum operator's safety

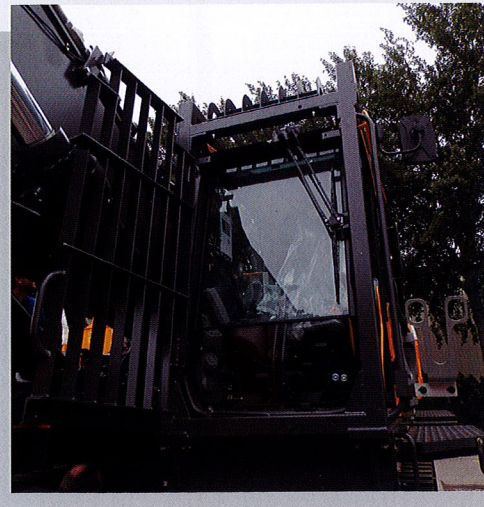

- Frame mounted
- Front guard and top guard can be opened for e.g. cleaning
- Roof window laminated safety glass

Transport dimensions

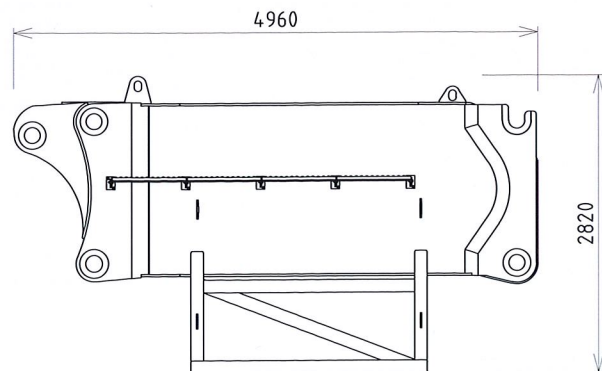

Boom extension adapter

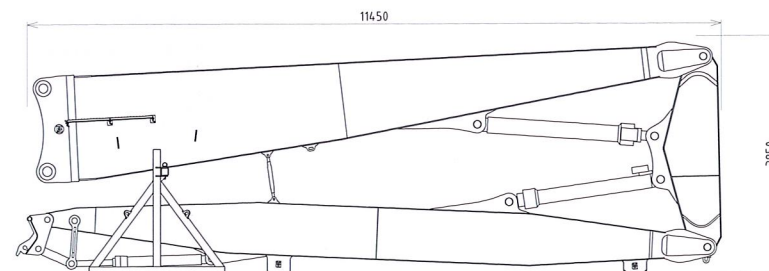

High Reach Demolition front

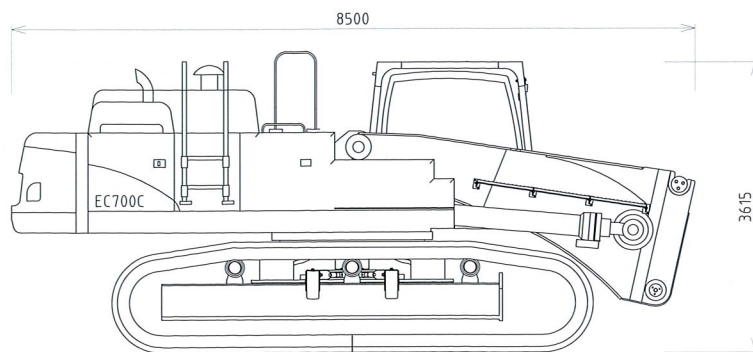

Base machine

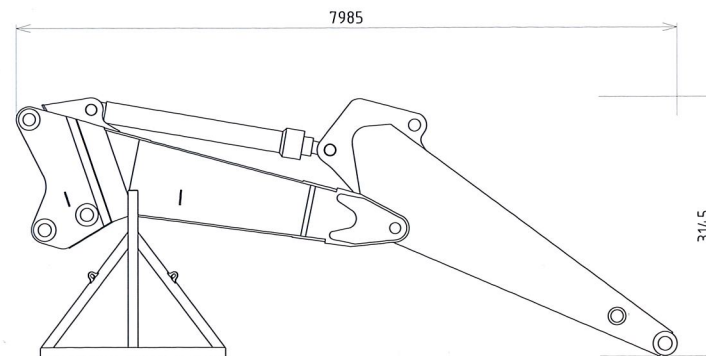

Digging front





Smart. Solid.

BECO | TRANSPORT

Tipper trailers and hooklift carriers
for agricultural, earthmoving,
landscaping and industry.

BECO | ATTACHMENTS

Equipment and attachments for excavators,
wheel loaders and cranes.

BECO | MODIFICATIONS

Modifications and components
for excavators, wheel loaders,
dump trailers and construction machines.

BECO | GRABS

Grabs for material handling, contractor,
waste processing, dredging,
recycling and industry.

BECO | STEEL STRUCTURES

Customized steel structures for onshore,
offshore and industry.

BV BECO

De Limiet 18

T: +31 (0) 347 - 323100

4131 NR Vianen (Ut.)

F: +31 (0) 347 - 377780

The Netherlands

E: info@beco-vianen.com

www.beco-vianen.com

www.facebook.com/beco.vianen